



246 • 19" subrack 6 U „Heavy Load“

19" subrack 246 "Heavy Load"

This heavy load subrack was especially designed for rough environments to ensure efficient electronics such as railway technology, energy and power stations, for strongly vibrating machineries or defence industry.

Strengthened and extended front brackets as well as double fixed module rails stand the test at high load due to shock and vibration. Further more, higher weight capacities can be taken. This has been confirmed by an independent institute by tests for resonance, vibration and shock acc. to IEC 61587-1 (2012-09) DL3 and static load acc. to SL1.

Its EMC compatible design has been approved by test acc. to VG95373, part 15, with a high interference resistance within a frequency range of 30 MHz up to 2 GHz.

All accessory components like card guides, handles, etc. of the standard series 245 can be used.

Material:

aluminium anodised

Delivery:

unmounted, kit form (without backplane and expansion kit)

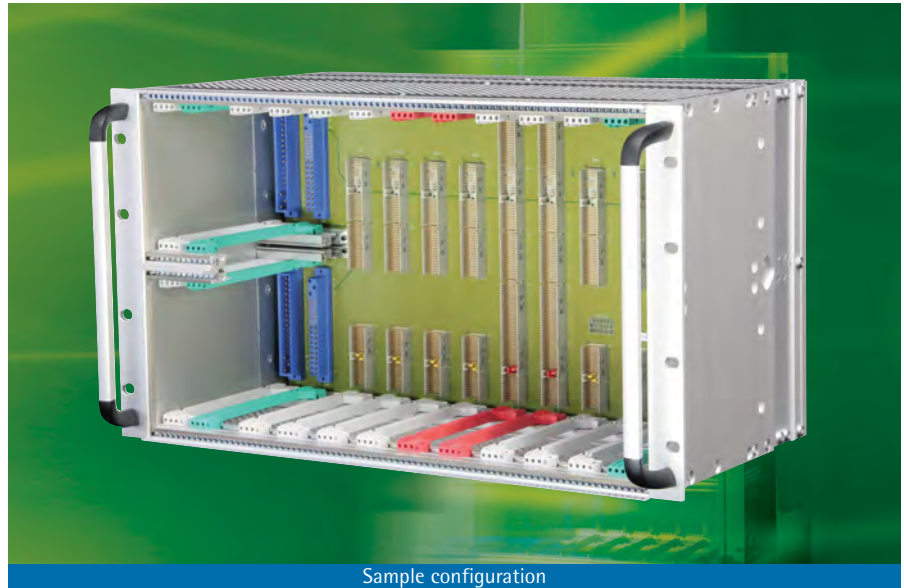

Sample configuration

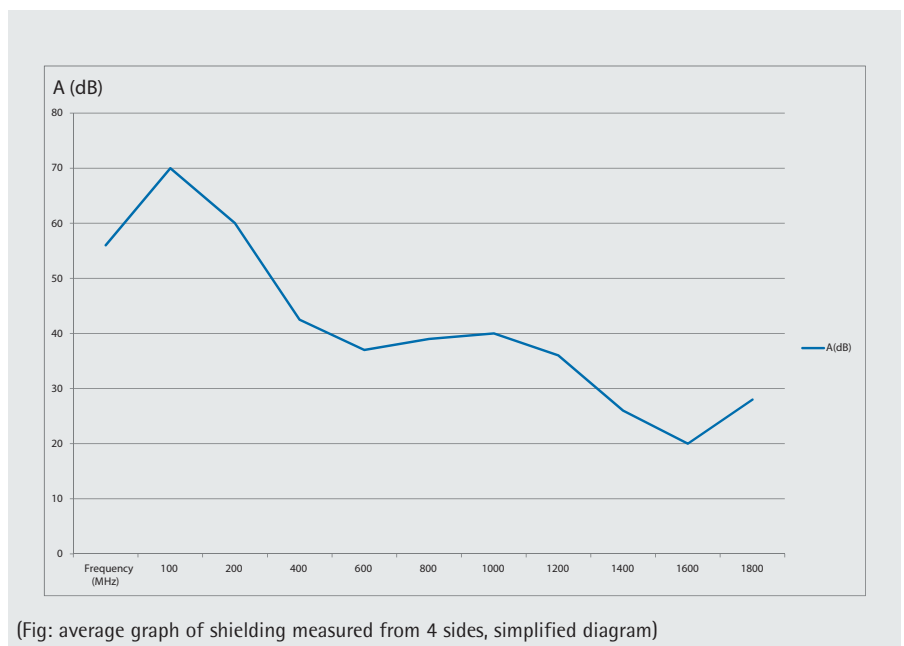
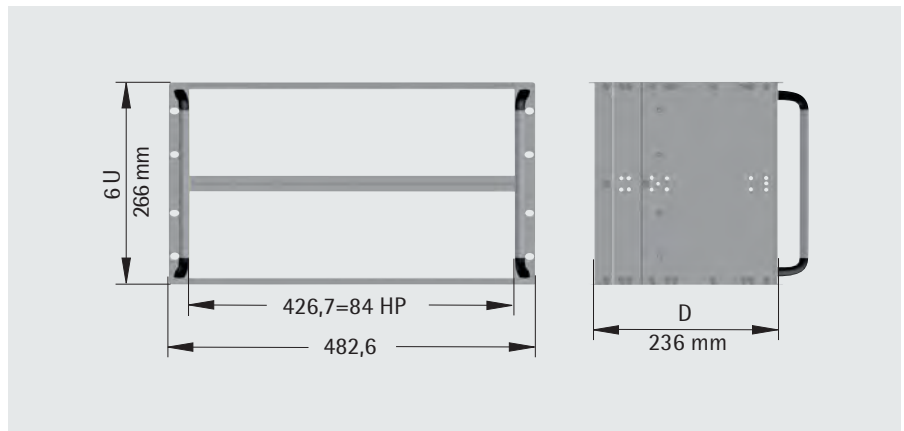

(Fig: average graph of shielding measured from 4 sides, simplified diagram)

Please ask for preassembly, cabling, ventilation, power control or backplane.

Order no. 246-660-00
